

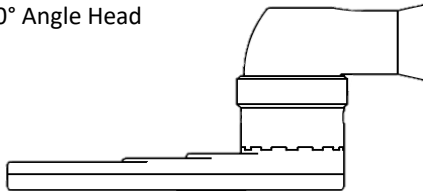

Inquiry Form

From	
Name:	
Company:	
Phone:	
Email:	
Date:	
Project:	

To	
Name:	Sales Department
Company:	E-Tech Industrial Corp.
Address:	121 Skyline Drive PO Box 35 Troy, Pa 16947
Phone:	+1 (570) 297-1300
Fax:	+1 (570) 297-1306
Email:	info@etechind.com

Style of Attachment:			
Open Ended	Closed Ended		
Target Torque:		+/-	
Please specify units			
Power Tool Model:			

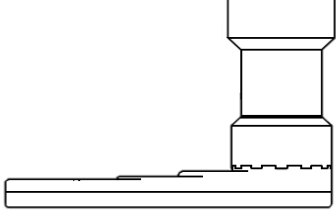
Adaptation Style Select one	
90° Angle Head	
Inline	
Pistol	

Output Socket	
Hex size:	
Socket Profile:	
Hex , Double Hex, Surface Drive, Bit Holder	
Extension Length:	
Hold Option Required:	
If yes, supply hold key dimension.	

If possible please provide a picture of the application.

Any Special Requirements Please Note Below:
Examples: Buddy socket, floating adapter, floating splindle, mounting, ect..

Inquiry Form

General Dimensions		Min.	Max.
Please specify Units			
Reach	A		
Width	B		
Nose Radius	R		
Height	H		
Tube Diameter	C		
Socket Center to Front of Attachment	E		

